

PS-3001 BASKET CENTRIFUGE CONTINUOUS SEPARATION

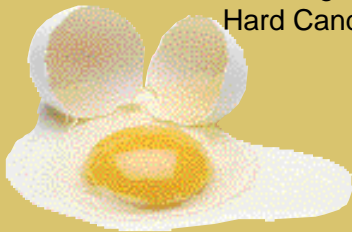

Washing & Dewatering Nuts,
Hard Candies, Dried Fruit



Separates Egg Liquid
From Shell

Grape & Wine Concentrating
Using Freeze/Ice
Crystal Technology

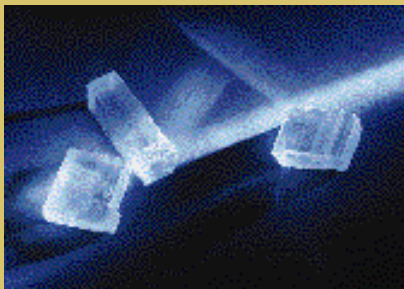

Washing Rice & Wheat
Grain Prior To Grinding
Into Flour/Meals

Dewatering Chemicals,
Plastics, Minerals and Crystals
in Chemical & Pharmaceutical Industry



FES International, Inc.
A WORLD LEADER IN PROCESS TECHNOLOGIES

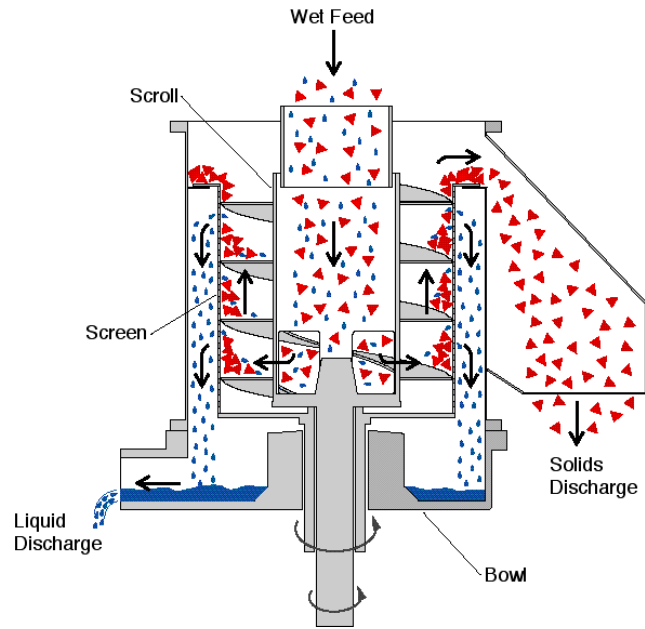
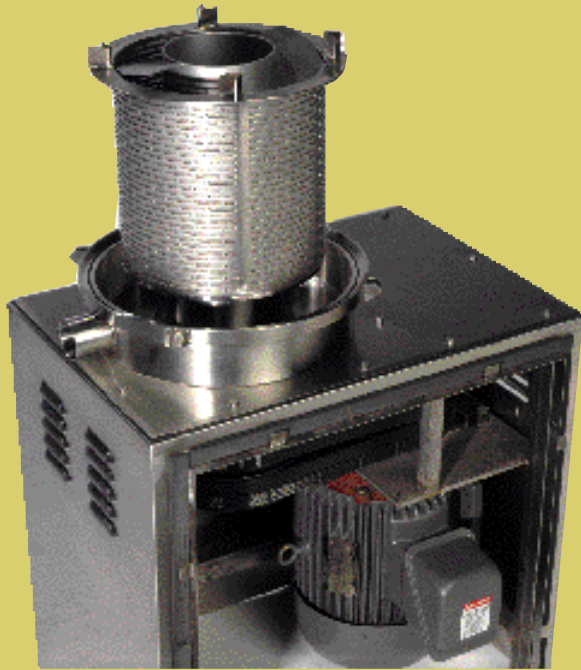

HOW IT WORKS

A mixture of solids and liquid is continuously fed through the top opening of the basket centrifuge. The rotating force of the centrifuge forces the liquid through a perforated or slotted basket. Liquid drains to the lower bowl and exits the machine through the liquid discharge pipe. The solids are contained within the basket and become dry as they are conveyed to the top where they exit through the solids discharge.

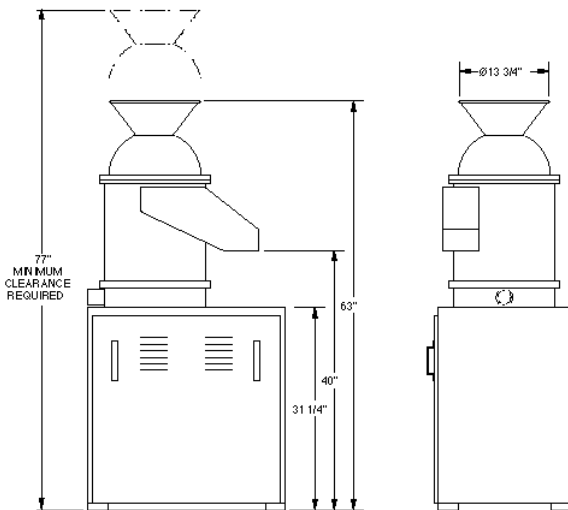
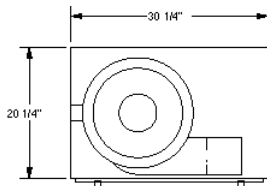

SPECIFICATIONS

- Heavy-duty construction
- All wetted parts stainless steel
- Industrial motor - oversized shaft & bearings
- Primary seals easily replaced
- Multiple discharge positions; change in field
- Low maintenance
- Capacity 50 gpm liquid
5000 lbs/hr. solids
based upon continuously metered flow
- Available 208/230/460/575 VAC, 60 Hz, 3 ph
220/380/415 VAC, 50 Hz, 3 ph
- Numerous basket types & sizes available
perforated screen .020", .030", .050", .078", .093"
slotted basket .001", .002", .005", .010", .015"



FES International, Inc.

A WORLD LEADER IN PROCESS TECHNOLOGIES
P.O. Box 1330 • Pomona, California, 91766 • USA
Tel: (909) 623-3174 • Fax: (909) 623-3674 • e-Mail: sales@fesintl.com